

Global Focus on Knowledge 2005

Science of Matter

The Production and Application of Matter

The University of Tokyo Hiroshi Komiyama

Professor Masatoshi Koshihara

Professor Katsuhiko Sato

How did matter come about?

Professor Hiroshi Iye

How are the characteristics of matter defined?

The figures, photos and moving images with ‡ marks attached belong to their copyright holders. Reusing or reproducing them is prohibited unless permission is obtained directly from such copyright holders.

1. The Structure and Properties of Matter

The properties of matter are attributed to the structure of matter.

Matter exists in different forms in the same crystal phase:

Hard and soft irons.

Colorless, yellow, and black diamonds.

Ductile, powdery, and smooth split silicon.

1.1 Dynamic Characteristics

Water does not start boiling at 100°C .

Water does not start freezing at 0°C .

Dynamic Models of Liquid Ebullition: Nucleation

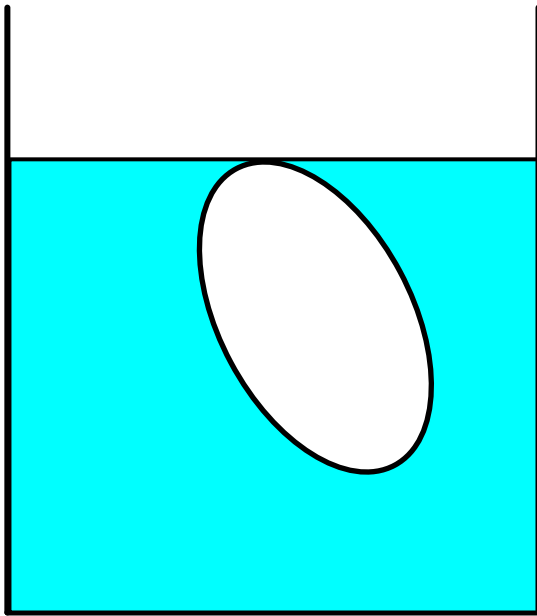

Bumping

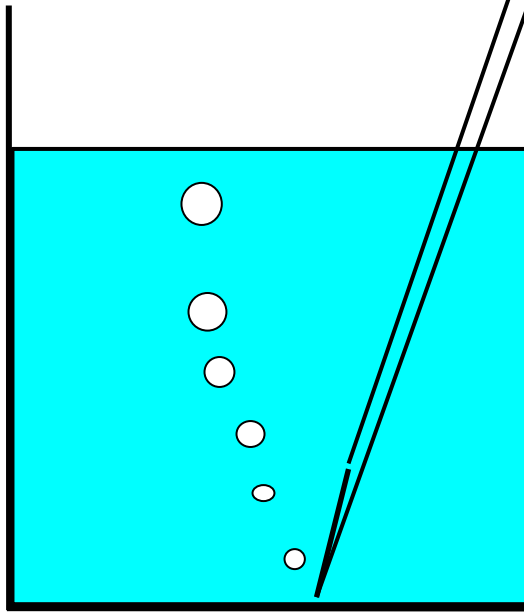

Capillary Tube

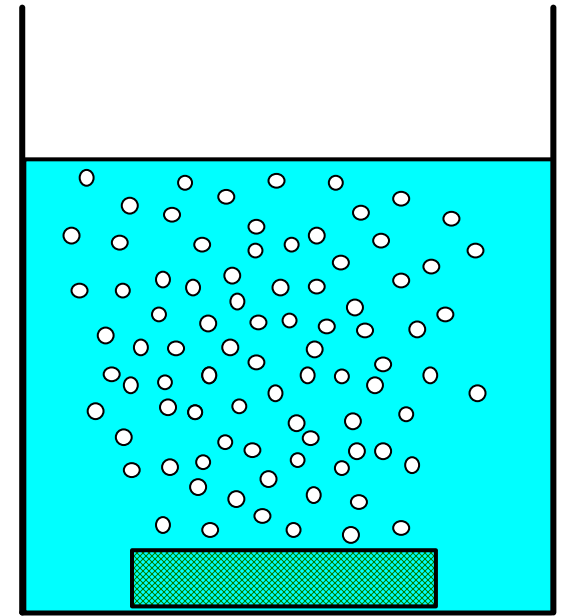

Madreporite

1.2 Structure Toward Infinity: Nucleation \rightarrow Crystal

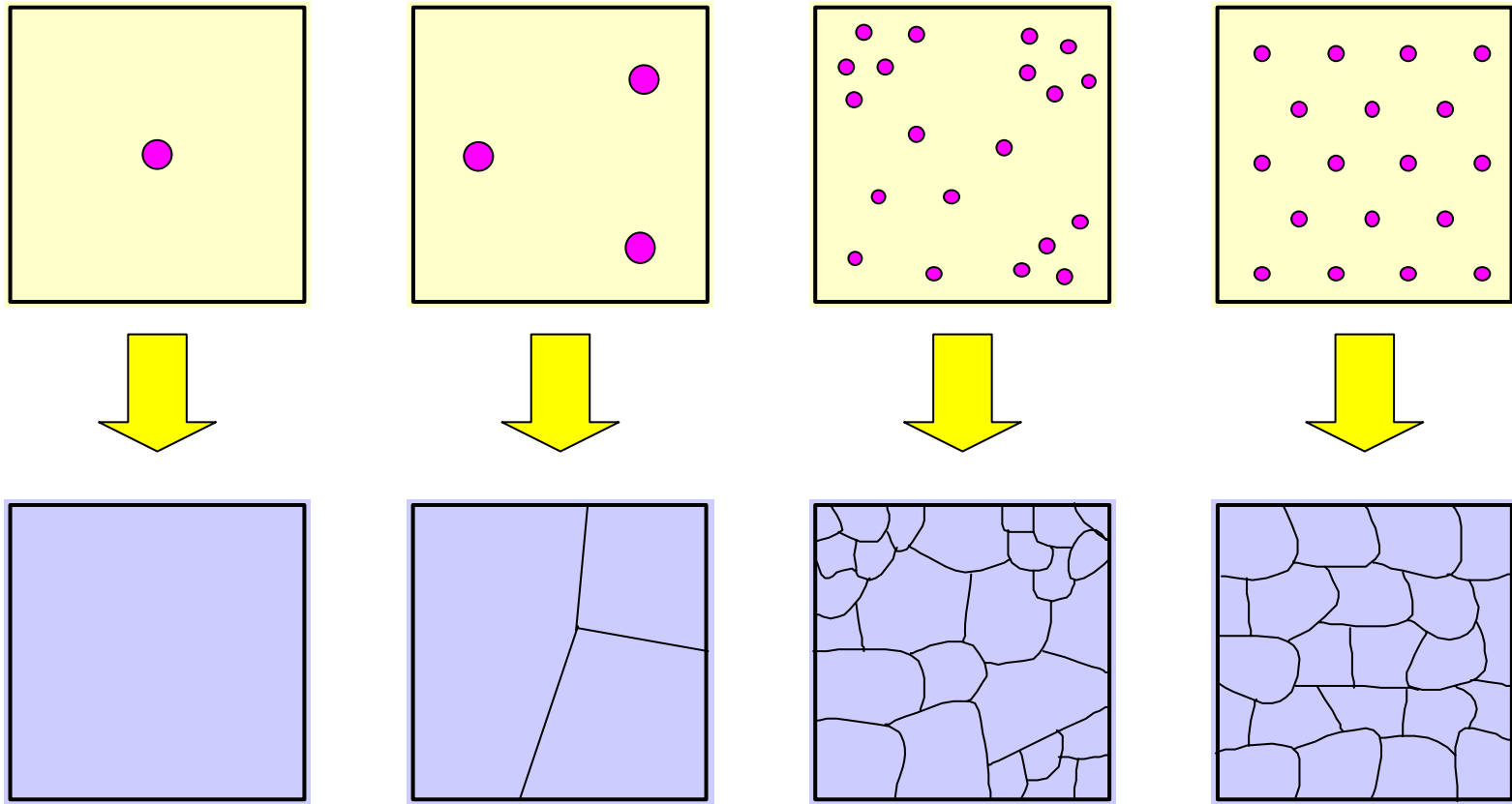

Monocrystal

Polycrystal

Uneven structure

Uniform structure

Structure Toward Infinity: Iron Phase Diagram

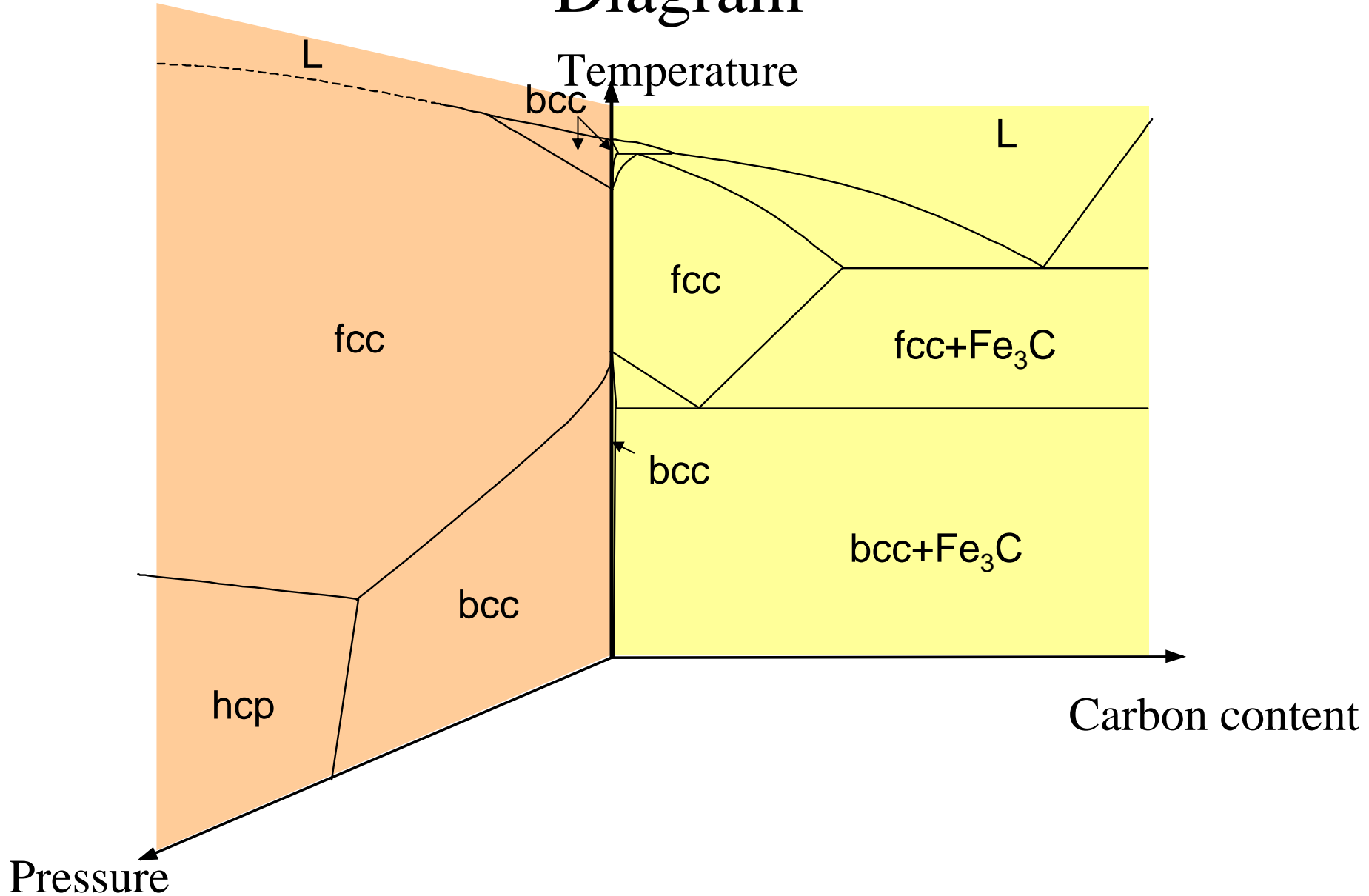

The Earth's Matter Exists in

1.3 Non-equilibrium States

120 ° C water and -10 ° C water.

Diamonds are in an equilibrium state under high pressure.

Iron oxide is iron's equilibrium state on the Earth.

Calcium carbonate in the ocean is oversaturated.

1.4 The Properties of Matter Are Attributed to the Structure of Matter

The same matter exists in an infinite number of different structures.

(Shape and size distribution of polycrystal) Infinite

× (Phase types) Infinite

× (Phase boundary) Infinite

→ Infinite

Natural phenomenon (nucleation and growth)

become mediator of the mechanism control.

1.5 The Definition and Elements of the Production Process of Matter

Definition: to realize a structure in a particular range out of all the structures of infinite possibility by making a phenomenon in a particular range proceed out of all the phenomena of infinite possibility.

Four Elements of the Production Process

Matter: chemical composition, crystal phase (includes amorphous phase), and impure matter (inclusions).

→Matter was covered in Dr.Iye's lecture.

Structure: polycrystal structure (includes amorphous), shape, size, uniformity, and dimension.

Velocity: generation rate

Conditions: principles, equipment, operations, materials, and control.

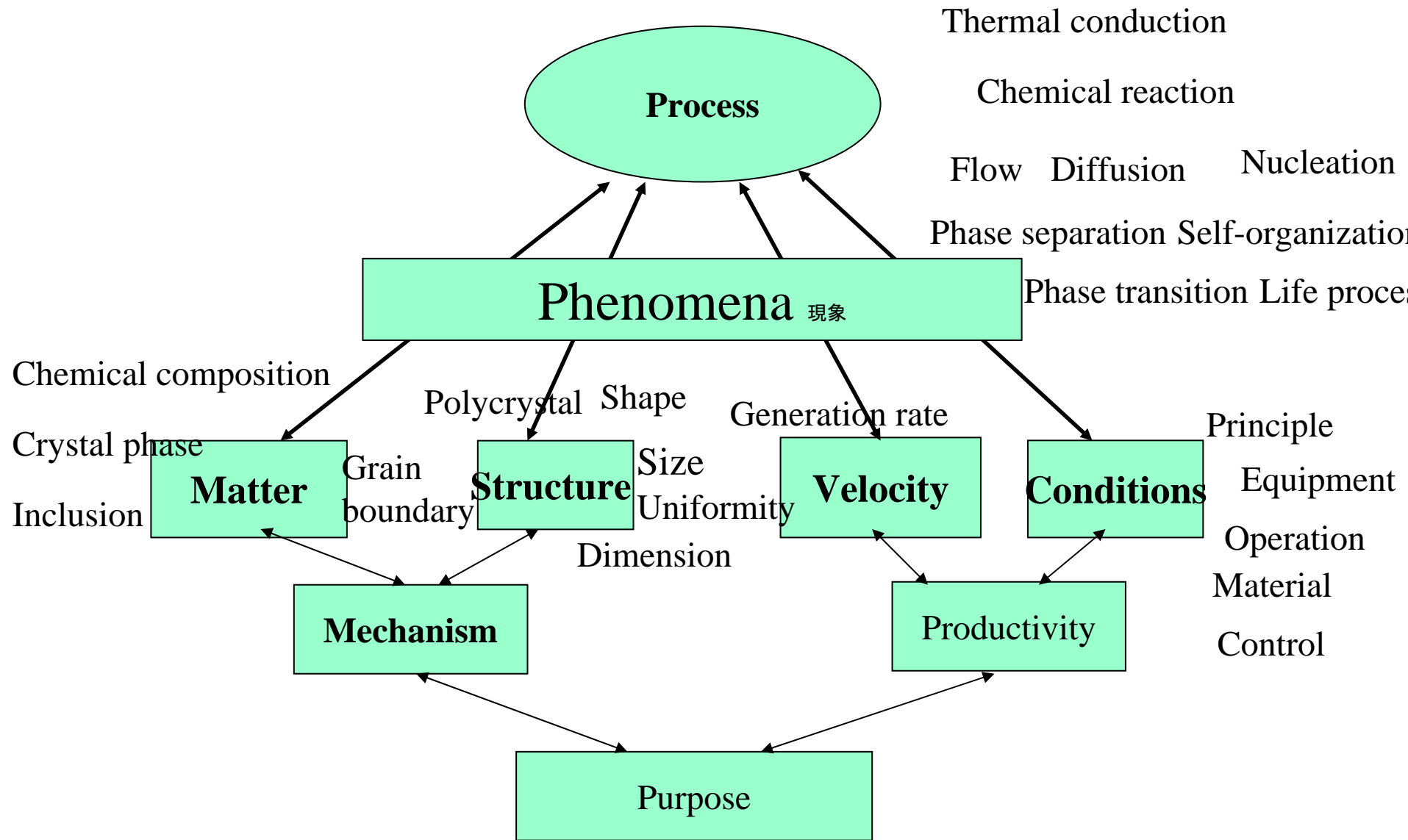

Applications of Iron and Steel Materials



2. Process Example: Iron Manufacturing

2.1 Pig iron making (blast furnace):

iron ore $\text{Fe}_2\text{O}_3 \rightarrow$ reductive reaction $\rightarrow \text{Fe}$

2.2 Steel making (converter)

2.3 Continuous casting (CC)

2.4 Hot rolling

Rolling (Strain rolling produces solid microcrystal grains)

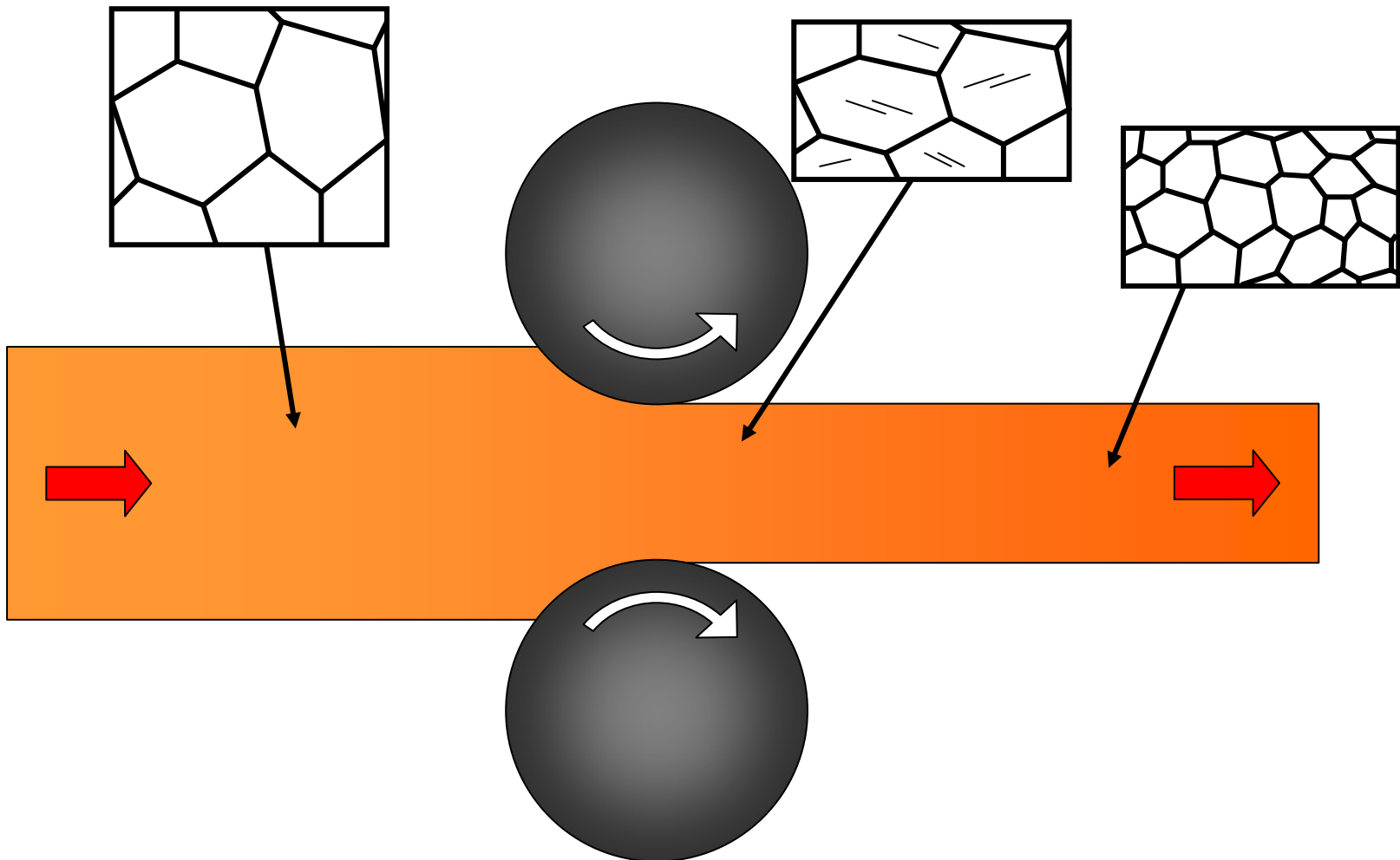

2.5 Outline of Iron Making Process

- Blast furnace (reduction of iron oxide)
- Converter (removal of impurities)
- Casting (liquid \Rightarrow solid)
- Rolling (micro-crystallization)
- Control: e.g., rolling:
 - pressure of rolls, temperature, velocity, uniformity (micron to kilometer), feedback, and feed forward.

2.6 Four Elements in the Production of Matter

Matter: composition, crystal phase, and impurities (inclusions).

Structure: polycrystal structure, shape, size, and uniformity.

Velocity: rate of process.

Conditions: principles of the process, equipment, operating conditions (temperature, pressure, and density), control, and measurement.

Matter and structure \Rightarrow “mechanism
(physical property)”

Velocity and conditions \Rightarrow “productivity”

Mechanism and productivity \Rightarrow “application
range”

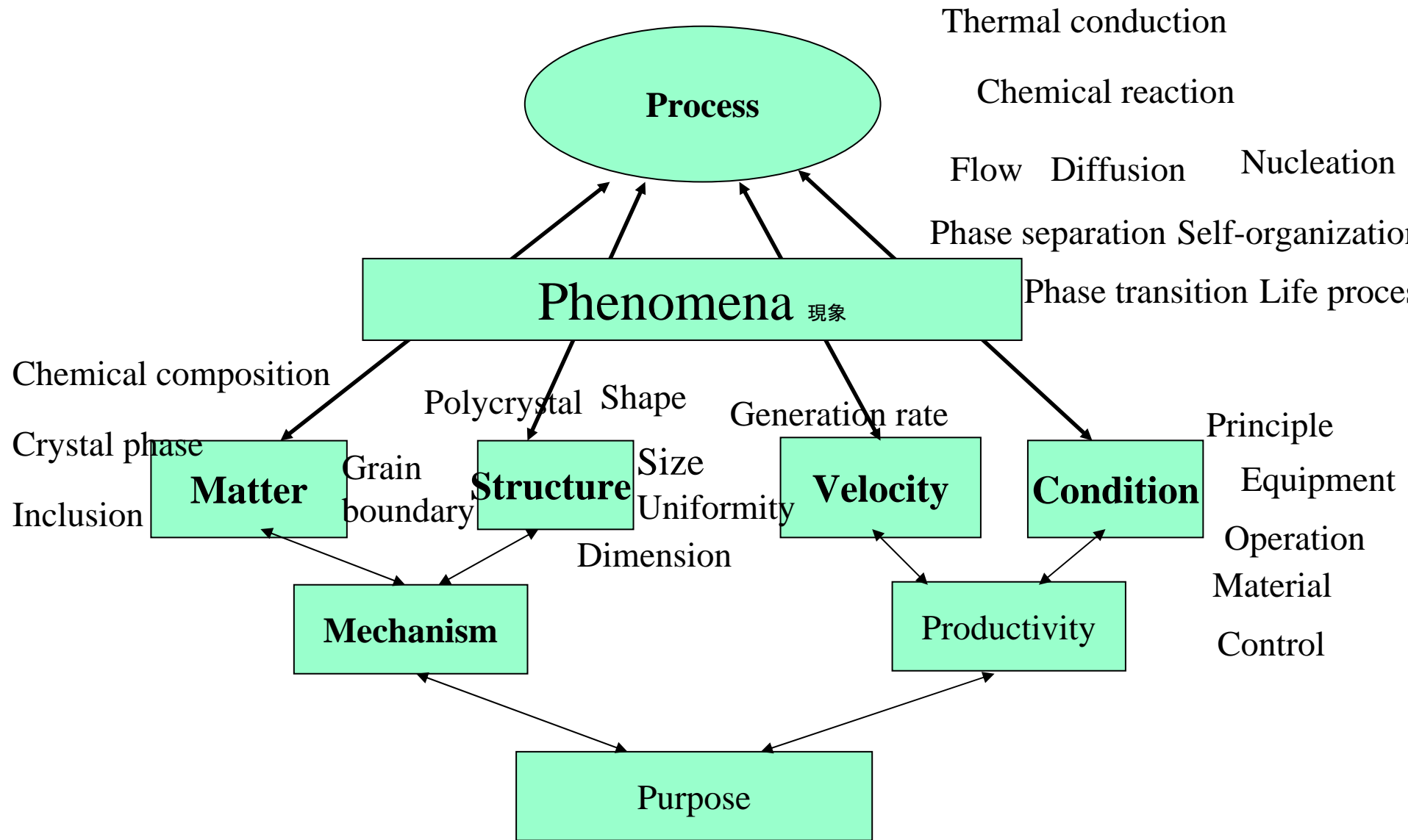

3. Functions and Applications (E.g., Iron and Steel)

3.1 Automobile sheet metal

High strength and ductility by control of phase transformation.

→Weight reduction and promotion of car collision safety.

3.2 Akashi-Kaikyo Bridge's wire rope

High strength obtained by self-organization at the nano-scale.

→Long-span bridge

3.3 Super metal

High strength obtained by the use of super-microcrystal grains.

→Strong and able to be recycled easily.

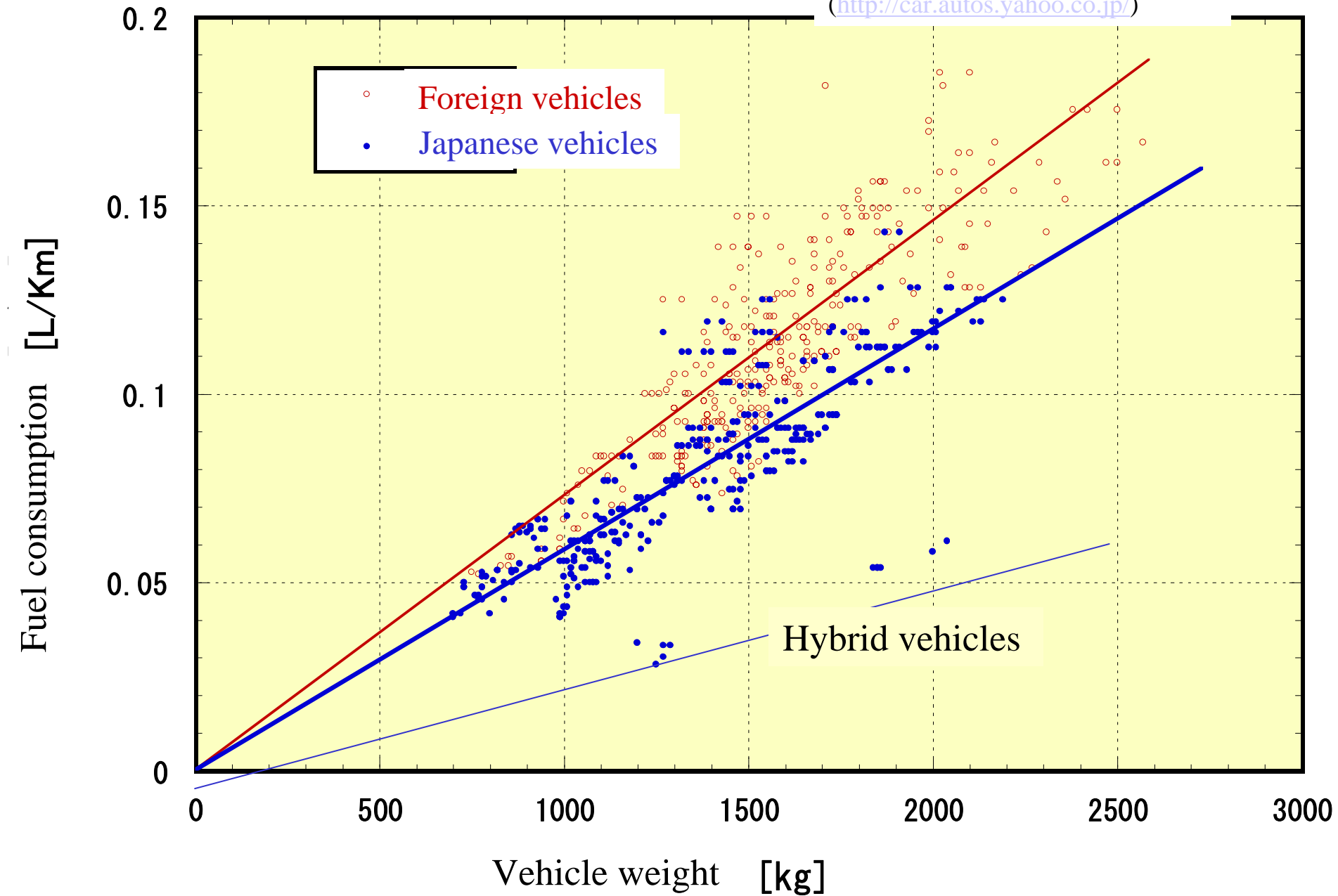

3.1 Structure and Energy

Absorption: High Strength Steel
Made by the Transformation
of Pressure Induction.

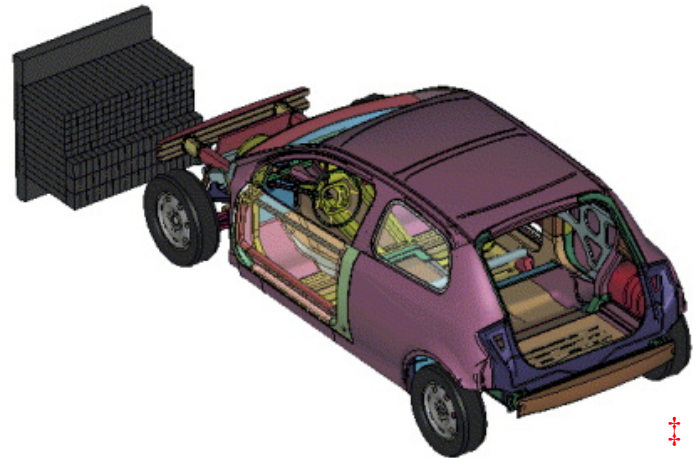

<Animation> : Front and side frame transformation equivalent to the plastic strain.

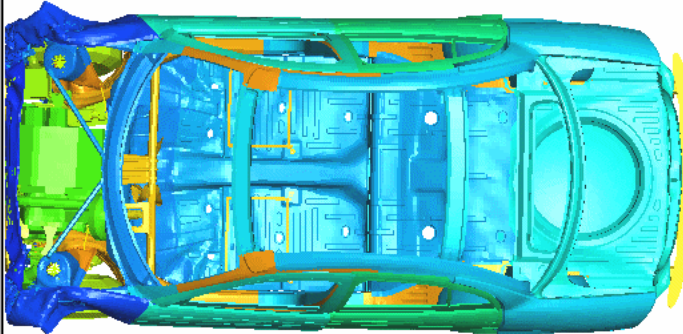
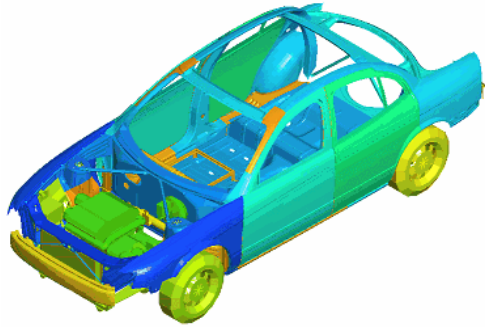

Vehicle body frames consisted only of the soft steel panels.

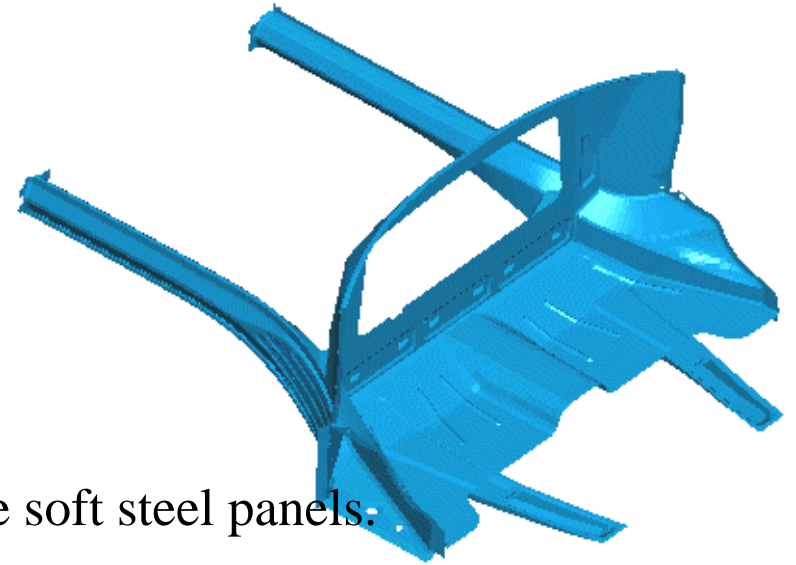

Rigid wall

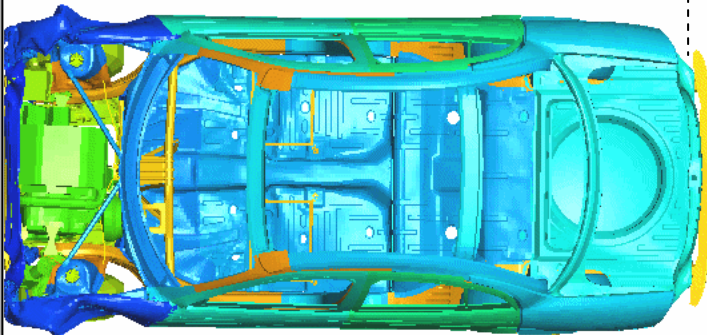

Vehicle body frames with adequate high strength steel panels installed.

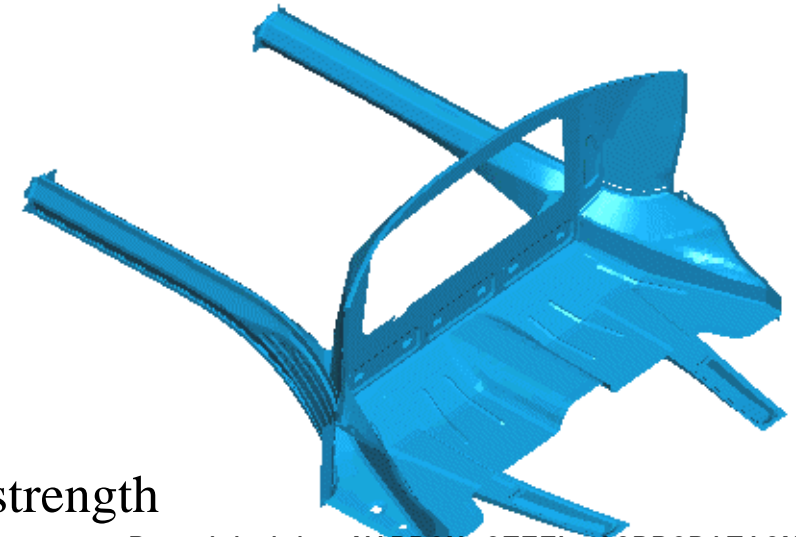

High Strength Steel Made by Process Inducing Transformation

In no time, (deformation and transformation \Rightarrow structure transformation \Rightarrow hardening)

Causing martensitic transformation \Rightarrow hardening

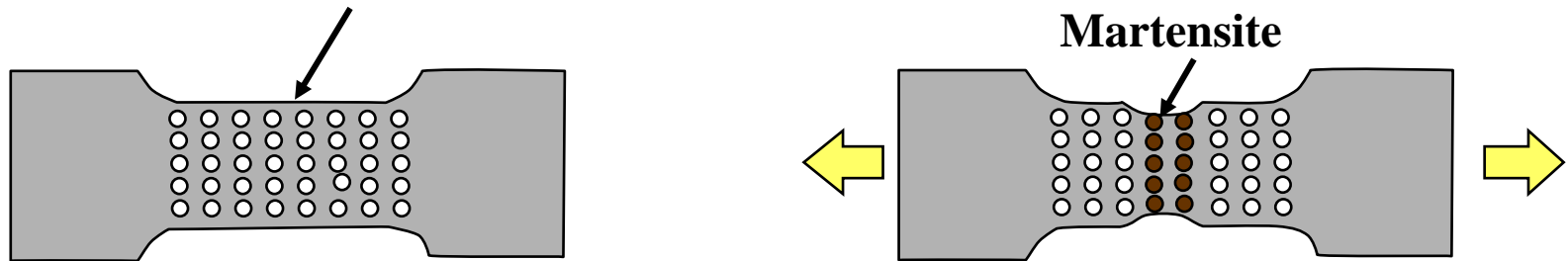
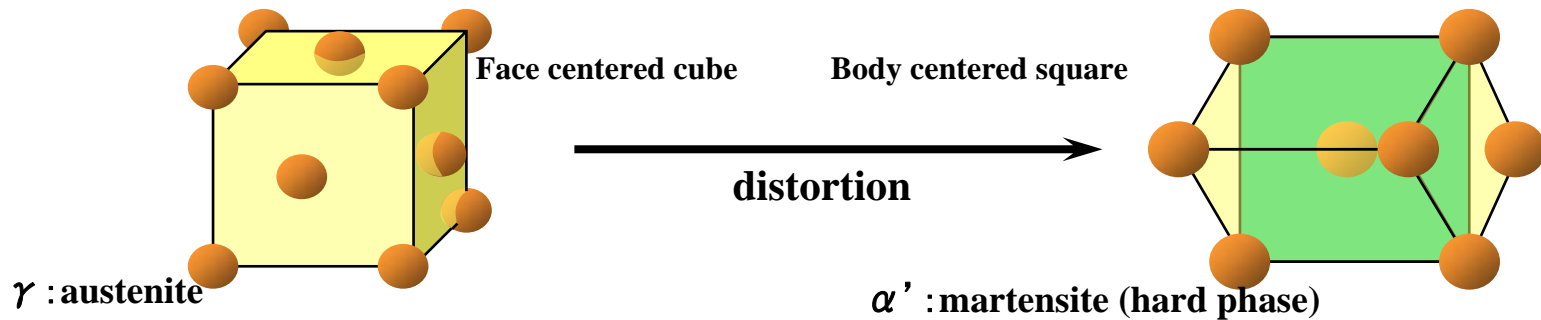

Distortion of austenite (soft) residual leads to the transformation into hard phase martensite; the distortion propagates evenly, and local necking hardly takes place; resulting in high ductility. .

Composition of TRIP Steel

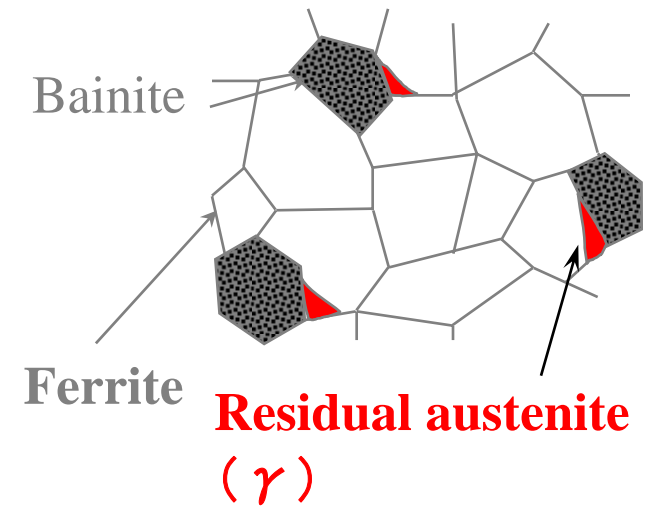
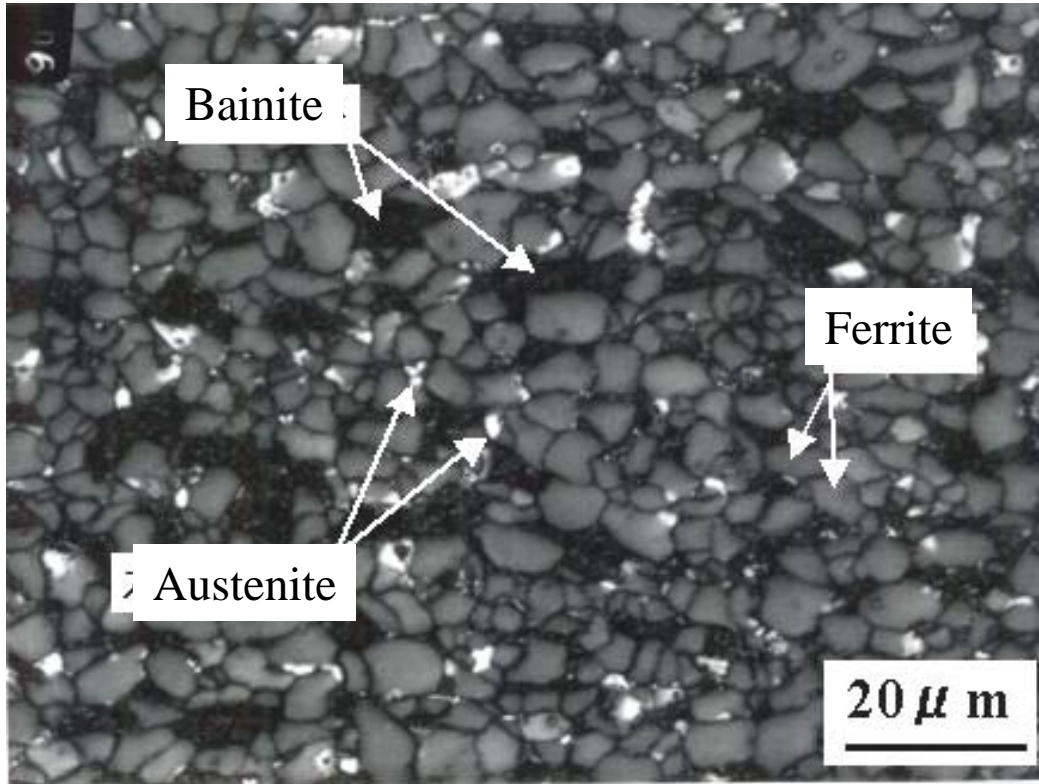

3.2 Akashi-Kaikyo Bridge's High Strength Steel:

The self-organization at the atomic level enabled the development of the high-strength wire rope used in the bridge.



Strengthening the Galvanized Steel Wire of the Bridge

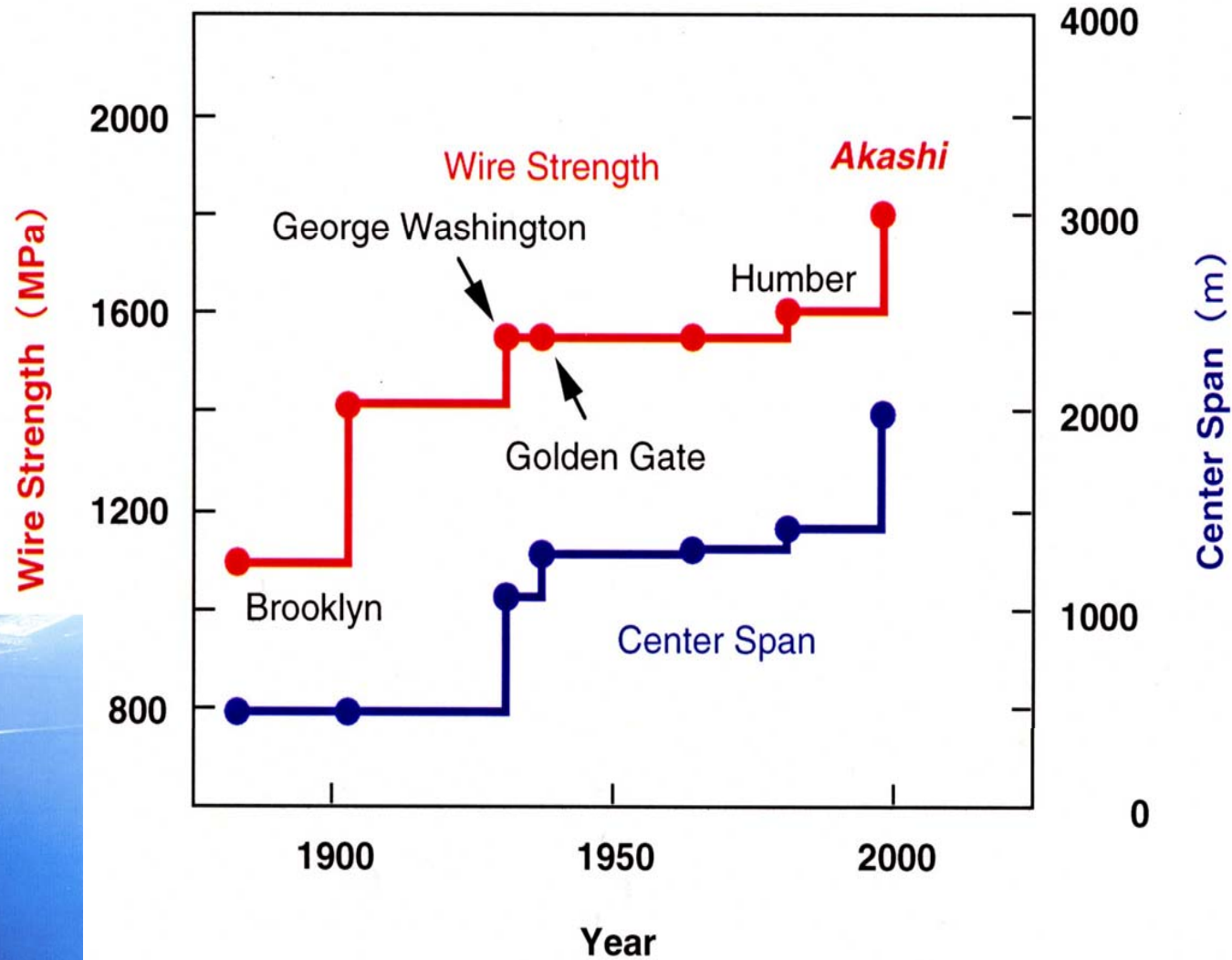

Akashi-Kaikyo Bridge: Cross Section of the Main Cable

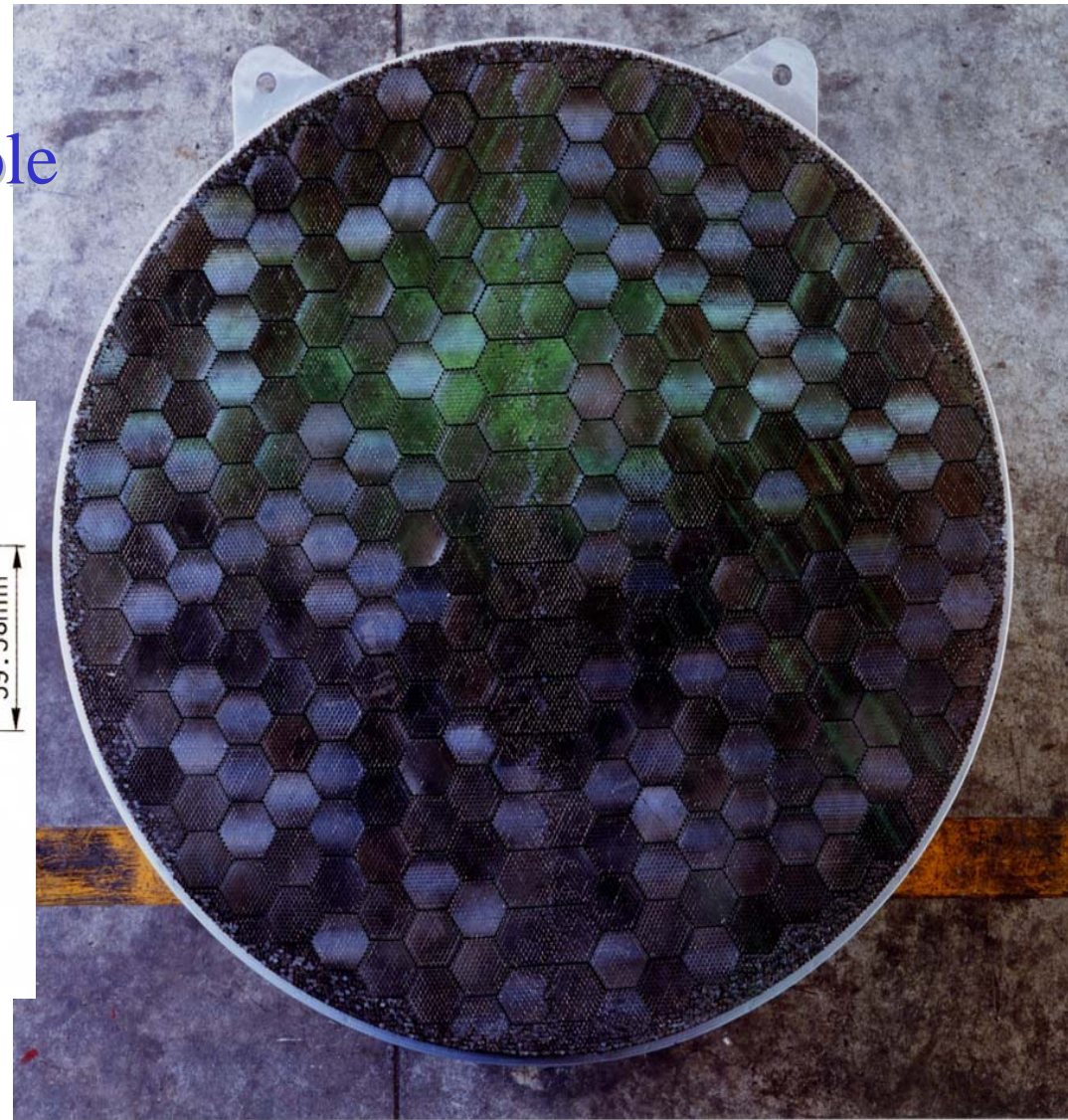
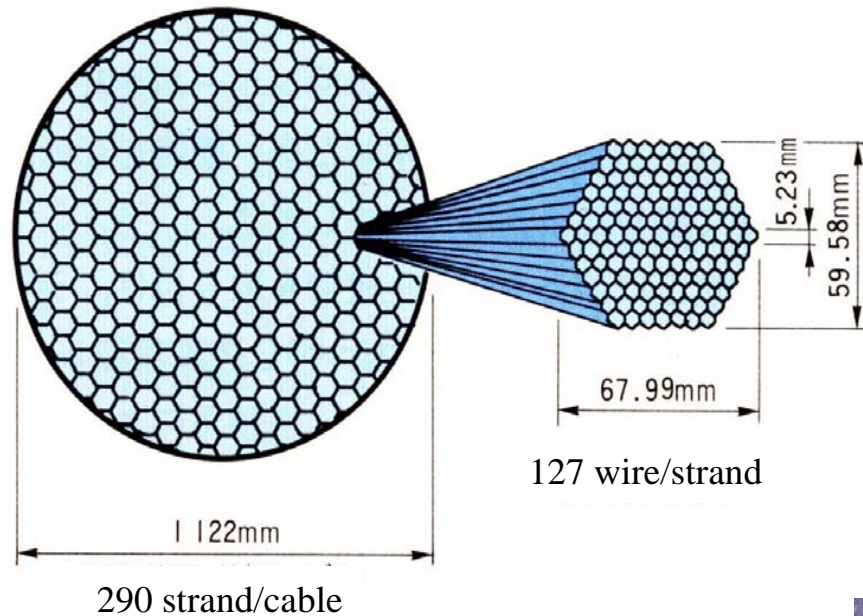

Cross section of main cable used for Akashi Strait Bridge.

Strength of galvanized wire	: 1800 MPa
Diameter of galvanized wire	: 5.28 mm
Diameter of main cable	: 1.12 m
Number of galvanized wire / cable	: 36,830
Weight of main cable	: 25,265 ton

Used in the Akashi-Kaikyo Bridge Now and the Wire Used in the After Galvanization of Si and Cr Addition Steel Wire Compositio

Provided by NIPPON STEEL CORPORATION

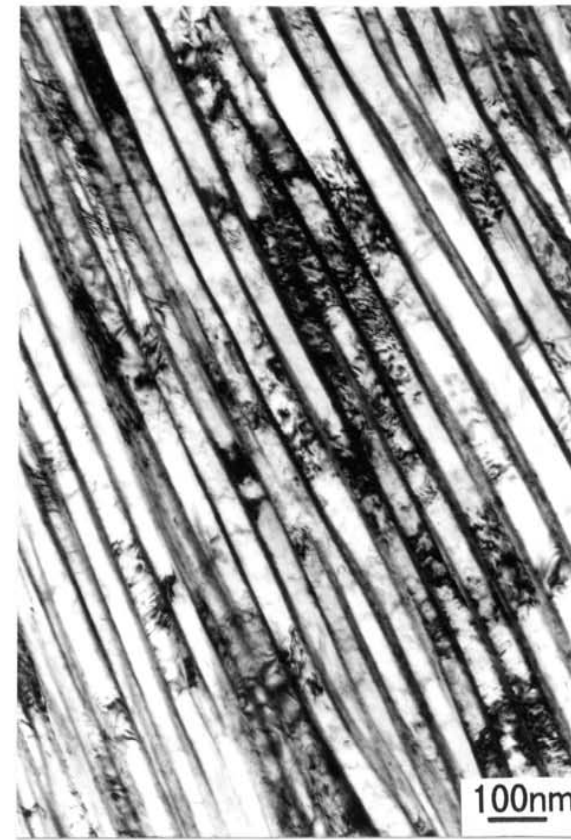
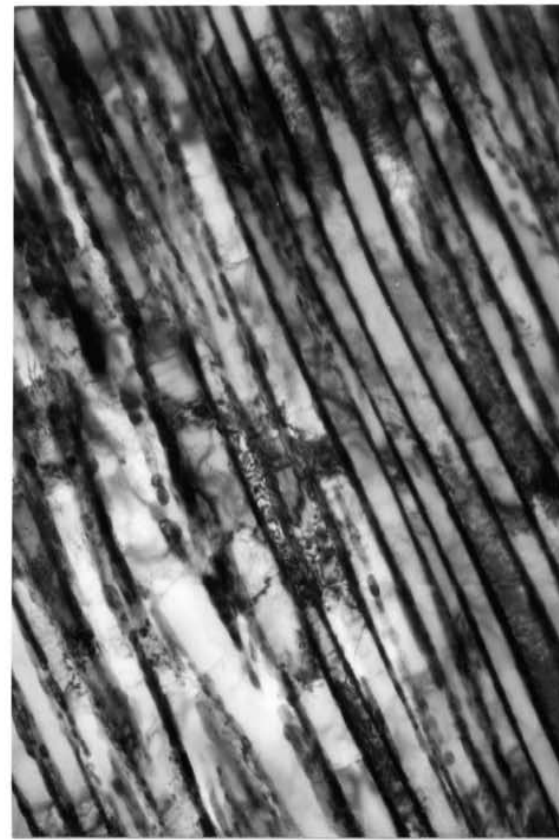

Steel used
previously

0.82%C

0.82%C-Si

0.82%C-Si-Cr

Transmission electron micrographs of wire aged at 450°C

AP-FIM of Steel Wire



TEM image of FIM sample.

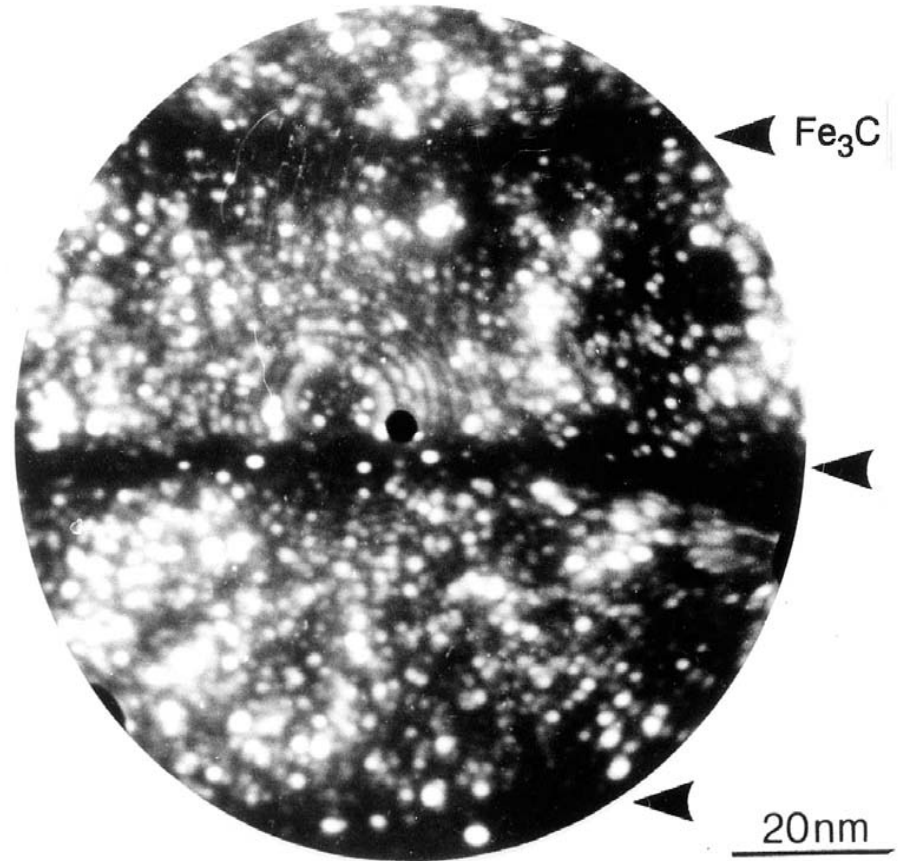

FIM

3.3 Super Metals

Social demands transition in chronology

Mass production of standardized ordinary products.

Efficiency promotion in the process.

Energy conservation, natural resource conservation, environmental coexistence, and automation.

High-function.

High tension and high tenacity.

Even higher function.

Car collision safety.

New demands and requirements.

Compatible materials in the durable society: energy saving and horizontal recycle.

Simultaneous Achievements

Recyclability

Iron is recycled → electric furnace

500 million tons out of 1 billion tons of steel production are recycled.

Recycling homogenizes the composition, and causes degradation.

Now iron recycling is used in construction materials.

Super metals

Structure control of just a single metal composition permits the exhibition of physical properties.

Crystal Grain-size Strengthening

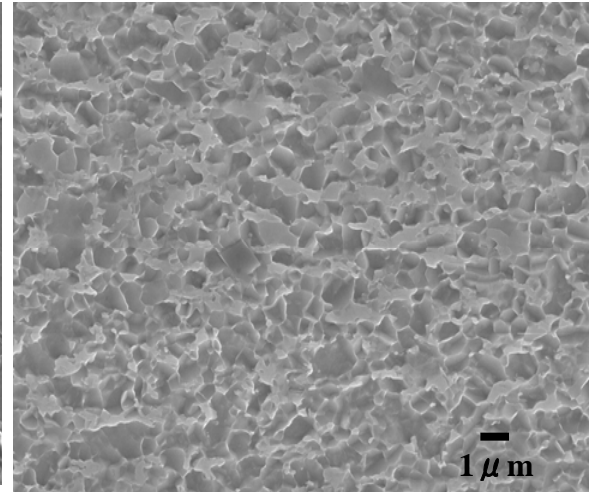
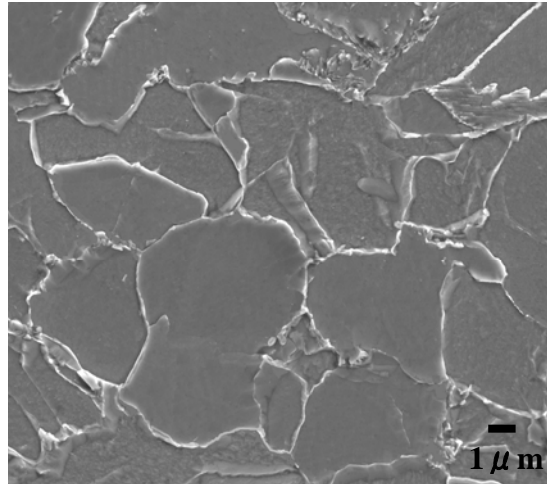
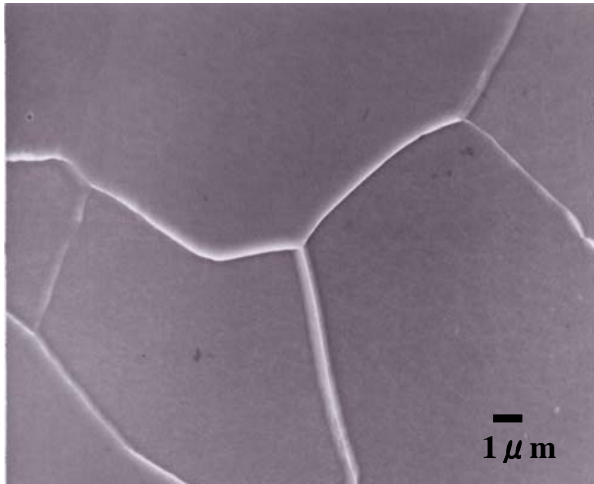

Original steel (left by rolling)

TMCP steel

Ultra-fine-grain
steel

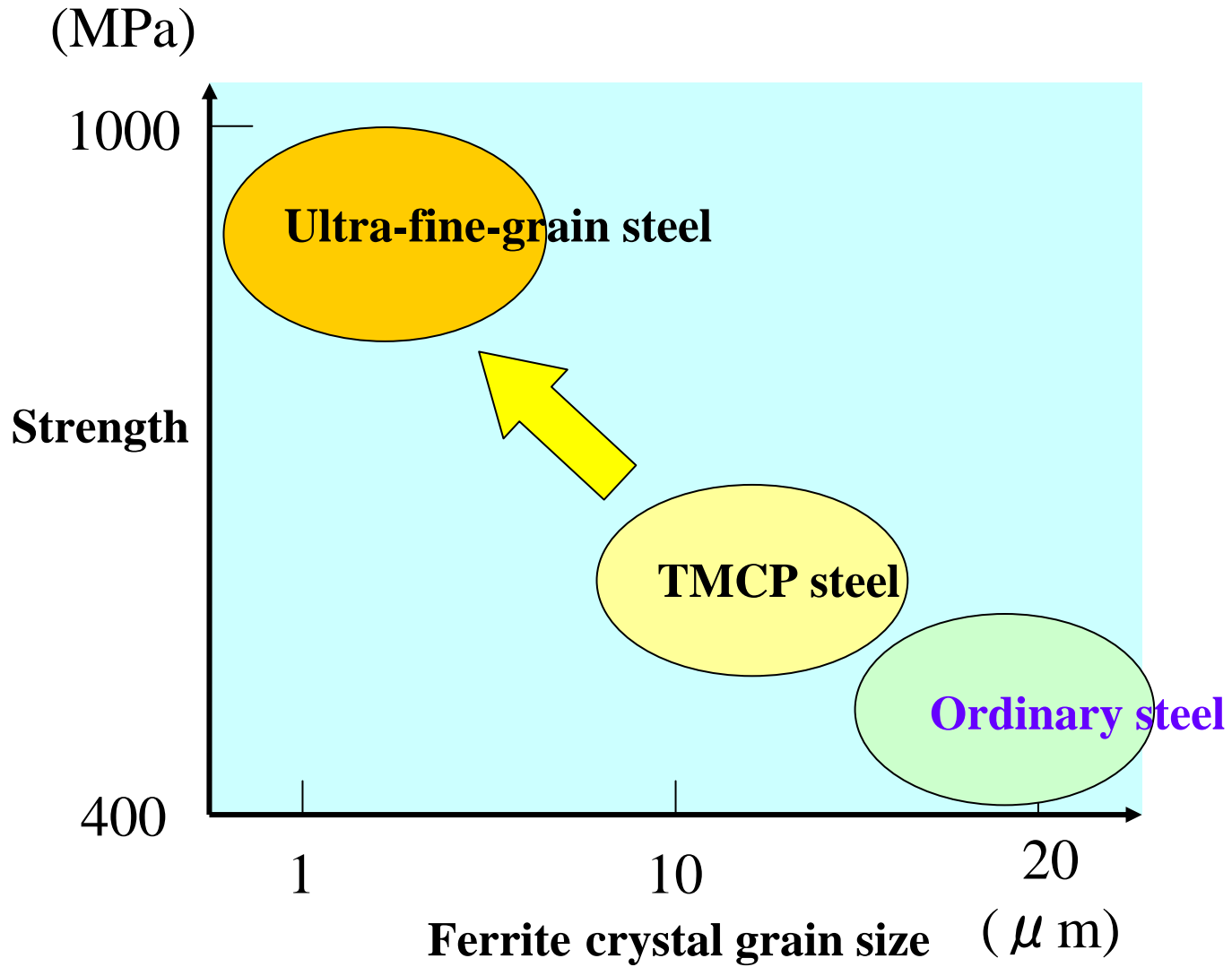

Figure 1. Strength increments along with crystal grain division.
(scheme)

The Definition and Elements of the Production Process

- Definition

To realize a structure in a particular range out of all the structures of infinite possibility by making a phenomenon in a particular range proceed out of all the phenomena of infinite possibility.

- Elements

Matter: Composition, crystal phase, and impurities (inclusions).

Structure: polycrystal structure, shape, size, uniformity, and thickness.

Velocity: rate of process.

Condition: principles, equipment, operation, heat control, and measurement.

4. Lecture Outline

Lecture One: Matter production process, e.g., metal (iron and steel).

Lecture Two: Conjugation (devices), e.g., semiconductors and inorganic materials.

Lecture Three: Soft matter, e.g., liquid crystals.

Lecture Four: Matter on durable earth (device), e.g., fuel cells and biochips.

End of Lecture One.